

Elevator overload control system  
EOS  
Technical passport



## Contents

1. Delivery set .....	3
2. Introduction .....	4
3. Labeling .....	4
4. Indication of safety measures .....	5
5. Preparation for work .....	5
6. Quick start-up .....	5
7. Indicator information .....	6
7.1. System configuration .....	6
7.2. Calibration .....	8
7.3. Possible malfunctions and methods of their elimination .....	11
8. Maintenance .....	12
9. Storage conditions .....	12
10.Delivery .....	12
11.Manufacturer's warranty .....	12
12.Description for the indicator models .....	13
13.Description for the load cell models.....	19

# 1. Delivery set

Kit designation EOS-\_\_\_\_\_ Indicator serial № \_\_\_\_\_

	<b>2</b>	<b>3</b>	<b>4</b>
<b>Indicator model</b>			

	<b>A</b>	<b>B</b>	<b>B1</b>	<b>C</b>	<b>CS</b>	<b>R</b>	<b>R1</b>	<b>W</b>	<b>W1</b>
<b>Load cell model</b>									

	<b>1</b>	<b>2</b>	<b>3</b>	<b>4</b>	<b>5</b>	<b>6</b>	<b>7</b>	<b>8</b>
<b>Number of load cells in kit</b>								

**Load cell serial №:**

	<b>No</b>	<b>M10</b>	<b>M12</b>
<b>Nuts</b>			
<b>Bolts</b>			

	<b>1</b>	<b>2</b>	<b>3</b>	<b>4</b>	<b>5</b>	<b>6</b>	<b>7</b>	<b>8</b>
<b>Number of nuts in kit</b>								
<b>Number of bolts in kit</b>								

	<b>Yes</b>	<b>No</b>
<b>Junction box with cable</b>		

**Quality control** \_\_\_\_\_

**Release date** \_\_\_\_\_

## 2. Introduction

This passport contains information about technical parameters, information on setting up, connecting and starting up the elevator overload system (EOS).

EOS consists of a primary and secondary converter. The primary converter consists of weight load cells, a junction box (if present) and a cable for connection to the secondary converter. The secondary converter is an electronic device EOS indicator (control unit).

EOS is not a measuring instrument. EOS is designed to control the load of the elevator cabin by analog-digital conversion of load cells signals into numerical values with their subsequent display on the device display, as well as the generation of discrete signals in relay outputs with the "dry contact" type connectors for signaling load levels or other digital or analog signal for elevator control system.

EOS is installed in places protected from corrosive gases and vapors.

EOS is installed on passenger, freight and other elevators, as well as elevators manufactured according to individual projects.

Before using EOS, you must carefully read this passport and undergo safety instructions.

All work must be carried out by authorized personnel.

## 3. Labeling

Labeling is applied to the front panel of the EOS control unit and should contain the following data:

- name and model of the device;
- the trademark and company name of the manufacturer;
- symbols of function keys;
- identification of indicating LEDs;
- power parameters;
- factory number.

### EOS kits designations

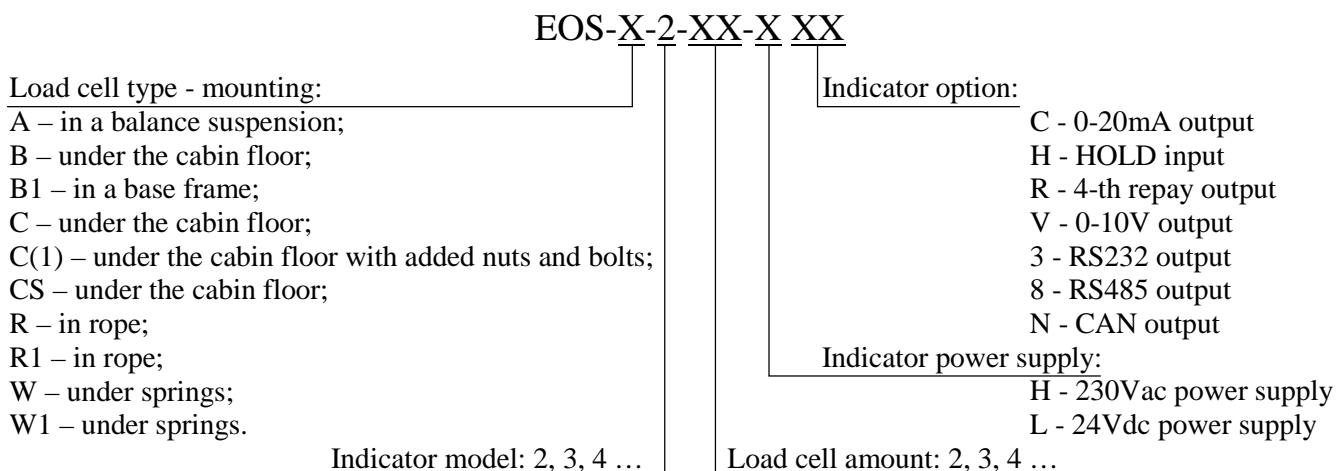

#### 4. Indication of safety measures

To work with the EOS, workers should know the safety rules when working with high voltage and are allowed to work with voltage up to 1000V.

It is forbidden to:

- operate an ungrounded appliance;
- open the case of EOS control unit or other parts of EOS, connect or disconnect the cables with the connected power supply to EOS control unit;
- apply to the load more than permissible.

#### 5. Preparation for work

Unpack and make a visual inspection for the integrity of the component parts of the device, as well as check the equipment. After unpacking, it is necessary to maintain the components of EOS at a temperature from +10°C to +35°C for at least 6 hours.

#### 6. Quick start-up

For kits with under the elevator cabin load cells the manufacturer made the calibration of EOS control unit on an exemplary force measuring machine. Recalibration of the EOS control unit device is required in case of replacing the load cells.



The quality control department (QCD) of the manufacturer carried out acceptance tests for compliance with the requirements of this passport, as recorded in section 1.

If it is necessary to recalibrate EOS control unit at the site of operation, it should be carried out with control weights (cargoes). The recommended total weight of reference cargo is not less than 20...50% F.S. Recalibration should be carried out according to the requirements of this manual.

With the power supply turned off, all the output contacts of the EOS control unit relays are in the state corresponding to the truth tables (see Table 1 and Table 2), all the LEDs are off.

Install load cells according to this manual section 13, connect load cells and indicator according to section 12 and section 13.





Turn on the EOS control unit.

With an empty elevator cabin, you must reset the weight. To do this, in the current weight display mode, press the buttons  +  to enter the user menu.

To zero the weight of the empty cabin, when the display shows an inscription «Zero» click the button . The ten-second countdown starts with an audible alarm. After nine short and one long signal, the weight of the empty cabin will be reset and exit to the user menu (the display will show "zero").

It is necessary to check the installed nominal elevator capacity, in case of a mismatch, change the parameter according to the procedure.

**Setup capacity (min 0kg, max is according to load cells F.S.).** In user menu. Press  to find “CAP” (setting the values of the set capacity in kilograms). To edit this

parameter, press the button , the current set value of capacity will be displayed on the screen. If editing is not required, press the button . To change the set capacity, use the button  to select the required digit of the number (the selected digit will flash) and the button  to change it. After setting the set capacity, press the button  to confirm the set value. After setting the capacity, relay thresholds values will automatically set for the operation of the passenger's presence relay (h15 - 15 kg), loading 90% (h90 - ninety percent of capacity) and overload (h110 - capacity plus 10% but not less than 75 kg).

In the process of loading the elevator, when the set values are reached, the corresponding relay contacts of the device are triggered, as evidenced by the illuminated indication LEDs.

**Note.** To exclude "bouncing" of relay contacts, each of them is triggered when the corresponding threshold (value) is reached, reverse triggering - when the load of the elevator decreases to a threshold level minus 5 kg.



## 7. Indicator information

### 7.1. System configuration

The EOS control unit is equipped with sound indication of power on, buttons operations and overload. Designation of buttons and connections are described at section 12 of this manual.

EOS control unit provides zeroing of the elevator cabin mass (value equal to F.S. minus elevator capacity). Also presented a function of automatic zeroing of the acquired weight in the specified range.

If it necessary, EOS control unit allows you to configure with the help of the service menu. The instrument is adjusted by the function buttons located on the front panel.

**To access the user menu,** in the current weight display mode, simultaneously press and hold the buttons  and . Block diagram of the operation with the user menu shown below.

Working mode

Zero weighting of the cabin





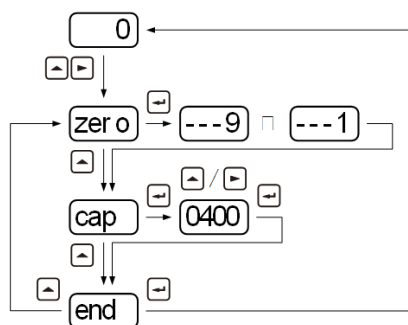

Set elevator capacity





Exit to the working mode











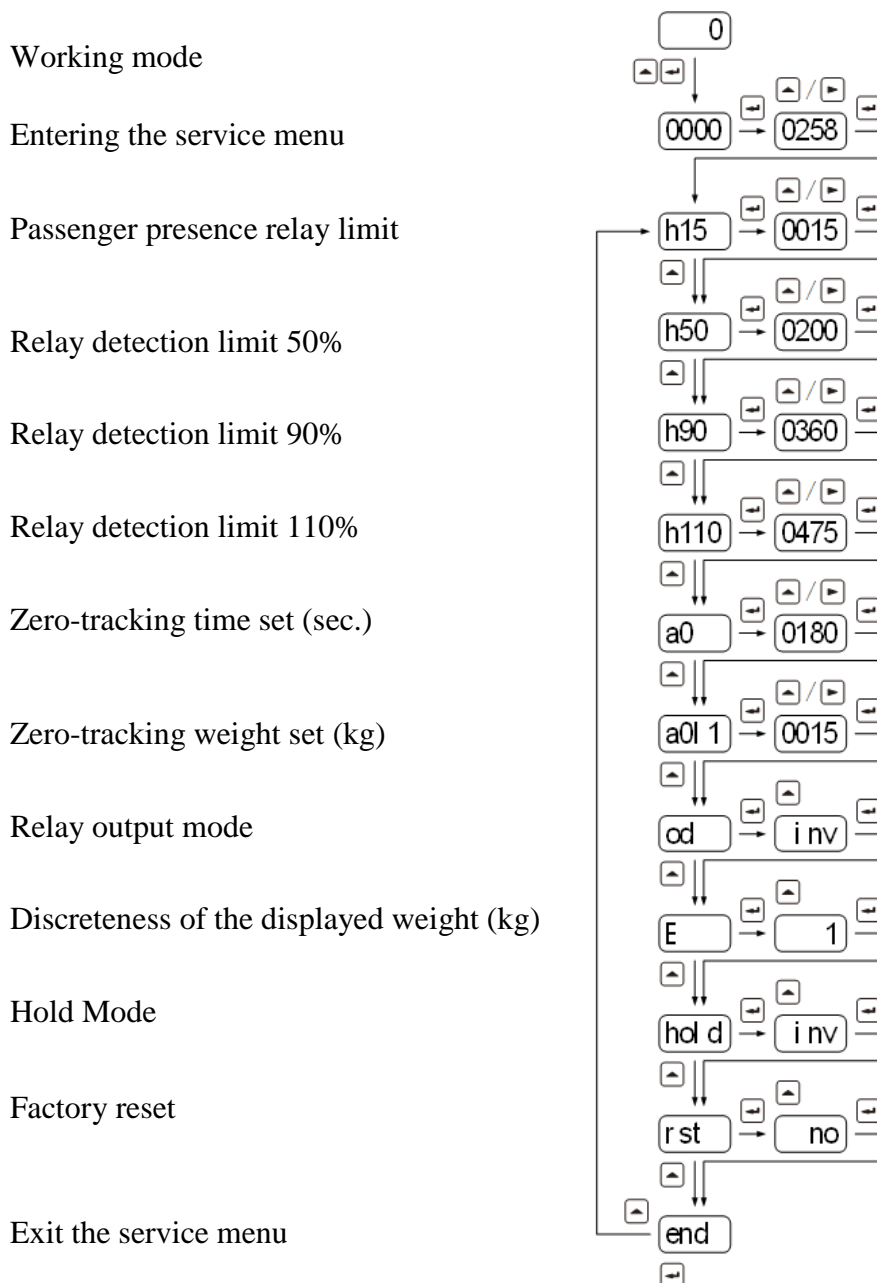











#### Parameters customizable in the user menu:

- **«Zero» - Zero weighting of the empty cabin.** To zero the weight of the empty cabin, when the display shows an inscription «zero» press the button . The ten-second countdown starts with an audible alarm. After nine short and one long signal, the weight of the empty cabin will be reset and exit to the user menu (the display will show "zero").





- **«CAP» - setting the values of the set capacity in kilograms.** To edit this parameter, press the button , the current set value of capacity will be displayed on the screen. If editing is not required, press the button . To change the set capacity, use the button  to select the required digit of the number (the selected digit will flash) and the button  to change it. After setting the set capacity, press the button  to confirm the set value. After maintaining capacity, automatic calculation and setting of the threshold values for the operation of the passenger's presence relay, loading 90% and overload (h15 - 15 kg, h90 - ninety percent of capacity, h110 - capacity plus 10% of it (but not less than 75 kg).
- **«End» - exit from the user menu.** To exit the user menu, press , the exit will be carried out and the display shows the measured weight.

**To access the service menu**, in the current weight display mode, simultaneously press and hold the buttons  and . Using  and  input password “0258” and press .



- **«H15» - setting the detection threshold weight** (min 0kg, max 50kg, default value 15kg). To edit this parameter, press the button , the current set value will be displayed on the screen. If editing is not required, press the  button. To change the set capacity, use the button  to select the required digit of the number (the selected digit will flash) and the button  to change it. After setting the set capacity, press the button  to confirm.
- **«H50» - setting the detection threshold for 50%F.S. (optional, might be hidden for some models)**. (min 0kg, max 9999kg, default value 200kg). To edit this parameter, press the button , the current set value will be displayed on the screen. If editing is not required, press the  button. To change the set capacity, use the button  to select the required digit of the number (the selected digit will flash) and the button  to change it. After setting the set capacity, press the button  to confirm.
- **«H90» - setting the detection threshold for 90%F.S.** (min 0kg, max 9999kg, default value 360kg). To edit this parameter, press the button , the current set value will be displayed on the screen. If editing is not required, press the  button. To change the set capacity, use the button  to select the required digit of the number (the selected digit will flash) and the button  to change it. After setting the set capacity, press the button  to confirm.
- **«H110» - setting the detection threshold for 110%F.S.** (min 0kg, max 9999kg, default value 475kg). To edit this parameter, press the button , the current set value will be displayed on the screen. If editing is not required, press the  button. To change the set capacity, use the button  to select the required digit of the number (the selected digit will flash) and the button  to change it. After setting the set capacity, press the button  to confirm.

**The relay set operation thresholds must satisfy the following condition:**  $h15 < h50 < h90 < h110$ . If an incorrect threshold is set or the value exceeds the permissible limit, when it is saved, the display will briefly show "Err" and will return to the setting of this value. A similar message will appear if other parameters are out of range during setup.

- **«A0» - setting the Zero-tracking time** (by default the function is disabled, range 0-180 seconds). The indicator's Zero-tracking function will enhance system temperature drift and drifting performance, if properly set. To edit this parameter, press the button , the current set value will be displayed on the screen. If editing is not required, press the  button. To change the set value, use the button  to select the required digit of the number (the selected digit will flash) and the button  to change it. After setting the set value, press the button  to confirm. When the value is set to 0s, the **Zero-tracking function is disabled**.











- «A0L1» - **setting the Zero-tracking range** (min 5kg, max 50kg, default value 15kg). To edit this parameter, press the button , the current set value will be displayed on the screen. If editing is not required, press the button . To change the set value, use the button  to select the required digit of the number (the selected digit will flash) and the button  to change it. After setting the set value, press the button  to confirm.
- «od» - **relays output mode** (normal logic or inverted logic, default value is inverted logic). In **normal** logic mode, relay works in **NC** way. When load is greater than set-point, the corresponding relay will open, otherwise it is closed. In **inverted** logic mode, relay works in **NO** way. When load is greater than set-point, the corresponding relay will close, otherwise it is open. To edit this parameter, press the button , the current set value will be displayed on the screen (“nor” or “inv”). If editing is not required, press the button . To change the set value, use the button  to change it. After setting the set value, press the button  to confirm.

Table of truth of logical levels of relay outputs in inverted mode is given in Table 1, where 1- relay is closed, 0 - relay is open.







**Table 1**

Inverse mode									
Normally closed					Normally open				
h	15	50	90	110	h	15	50	90	110
No power	1	1	1	1	No power	0	0	0	0
There is a power, level is not reached	0	0	0	0	There is a power, level is not reached	1	1	1	1
Limit passenger	1	0	0	0	Limit passenger	0	1	1	1
Limit 50%	1	1	0	0	Limit 50%	0	0	1	1
Limit 90%	1	1	1	0	Limit 90%	0	0	0	1
Limit 110%	1	1	1	1	Limit 110%	0	0	0	0

Table of truth of the logic levels of relay outputs in the normal mode is given in Table 2, where 1- relay is closed, 0 - relay is open.





**Table 2**

Inverse mode									
Normally closed					Normally open				
h	15	50	90	110	h	15	50	90	110
No power	1	1	1	1	No power	0	0	0	0
There is a power, level is not reached	1	1	1	1	There is a power, level is not reached	0	0	0	0
Limit passenger	0	1	1	1	Limit passenger	1	0	0	0
Limit 50%	0	0	1	1	Limit 50%	1	1	0	0
Limit 90%	0	0	0	1	Limit 90%	1	1	1	0
Limit 110%	0	0	0	0	Limit 110%	1	1	1	1

- «E» – **selection of discreteness of the displayed weight** (1 or 5 kg). To select, press , the display will show the current value "5" - 5kg or "1" - 1kg. Use the key  to select the required value and press the key  to confirm.
- «rSt» - **system reset** (YES or NO). Is used to reset all configurable parameters to their default value. To reset all parameters, press the button , press  to set “YES” and confirm reset or “NO” to cancel reset. After setting the parameter, press the button  to confirm.
- «End» - **exit the service menu**. To exit the service menu, press , the exit will be carried out and the display will show the measured weight.

## 7.2. Calibration

For calibration prepare the **calibration weight not less than 20...50%** of the elevator capacity.

**To access the calibration menu**, in the current weight display mode, simultaneously press and hold the buttons  and . Using  and  input password “8416” and press .

Working mode

0

0000

 / 

Enter password

8416





Calibration menu

cal



Set empty weight of the cabin



set 0

 ---9  ---1

Put the weight in the cabin and set calibration weight value

0400





 ---9  ---1

Exit the calibration menu



end



- In the calibration menu when “CAL” is displayed, press  for start calibration. When “Set0” shows, make sure the elevator cabin is empty (without any load) and press  to start zero calibration. Indicator will count down from 9 to 0. After nine short and one long signal, the weight of the empty cabin will be reset. When “400” shows, apply the calibration weight and set the value, using the button  to select the required digit of the number (the selected digit will flash) and the button  to change it. After setting the calibration value,

press the button  to confirm. Indicator will count down from 9 to 0. After nine short and one long signal, the calibration is successfully done.

- **«End» - exit the calibration menu.** To exit the calibration menu, press , the exit will be carried out and the display will show the measured weight.

### 7.3. Possible malfunctions and methods of their elimination

In case of a malfunction, try to eliminate them using Table 3. If the fault is not found in the table, contact the manufacturer's service center. Independent changes in the design or self-elimination of other malfunctions that require intervention in the design of the device may result in failure of the warranty service. Possible faults and methods for their elimination are given in Table 3.

**Table 3**

Malfunction	Possible reason	Method of elimination
The device does not turn on	No power supply	Check if power is applied, if not, turn on the power
	Power options do not meet the requirements	Supply the required voltage and frequency
With an empty elevator cabin, the weight is different from 0	Zeroing not performed	Reset the empty cabin weight
Incorrect weight readings	Incorrect calibration	Perform calibration
	Bad contact between connecting wires and load cells / indicator	Reconnect wires to connector
Relays are triggered at incorrect value of the measured weight	Incorrect set for relay thresholds	Reset the relay detection thresholds
The device does not react to loading the cabin	Load cells commutation is wrong	Recheck commutation of load cells according to this passport.
	Load cell(s) is broken	Replace a load cell(s)
Incorrect operation of the relay	Wrong commutation	Check commutation, change if it's necessary
	Wrong relay output mode is selected	Change relay output mode
Automatic zero don't work, cabin empty weight accumulated	Range of automatic zero are not enough	Range of automatic zero should be increased
	Friction between cabin and rails	Eliminate friction
The weight in the cabin changes randomly	Incorrect calibration	Perform calibration with known weight

## **8. Maintenance**

Maintenance of EOS must be carried out in accordance with the requirements of this passport and in the manner prescribed by the operating instructions for the elevator in which it is used. All work related to maintenance should be carried out with strict adherence to safety regulations.

## **9. Storage conditions**

EOS must be stored in a closed warehouse. Storage conditions must comply with IEC 62435 for general electronic devices.

## **10. Delivery**

Delivery must be carried out according to the requirements of the contract.

## **11. Manufacturer's warranty**

The manufacturer guarantees that the EOS complies with the data in this Passport if the consumer complies with the required storage, installation and operation conditions.

The warranty period is 36 months from the date of purchase. Guaranteed shelf life is 60 months from the date of manufacture. During the warranty period, the manufacturer is obliged to replace or repair the EOS free of charge, if the customer finds any failures in operation or any inconsistency with the parameters specified in this Passport.

During the warranty period, in case of EOS failure or regular failures in operation, the consumer informs the manufacturer (manufacturer's representative):

- the nature of the failure;
- the consequences of failure;
- probable causes that could lead to failure or malfunction.

Complaints should be sent to the official representative (supplier) of the manufacturer.

Supplier contact information:

LIMITED LIABILITY COMPANY VAGAR

(VAGAR SPÓŁKA Z OGRANICZONĄ ODPOWIEDZIALNOŚCIĄ)

Address: Office 35, 3, Franchishkanska Street, Warsaw, Poland, 00-233

tel.: +48 222 304 536

email: [info@vagarload.com](mailto:info@vagarload.com)

## 12. Description of the indicator models

### EOS-2 control unit

№	Parameter name	Value
1	Power supply	230±20 VAC 50±1 Hz 24±4 VDC (optional)
2	Power consumption, no more than	6 W
3	Maximum current switched by relay outputs at voltage 220VAC or 24 VDC	10 A
4	Operating mode	continuous
5	Number of programmable relay outputs	3 or 4 (optional)
6	Setting threshold range loading presence of a passenger 50% (optional) 90% 110%	Set in kg 0-50 kg 0-9999 kg 0-9999 kg 0-9999 kg
7	Number of digits of the display	4
8	Operating temperature range	-10...+50°C
9	Humidity	15...95%
10	Degree of protection for IEC 60529 (DIN 40050)	IP54
11	Average full-service life, not less than	10 years
12	Lower limit of transformations	1 or 5 kg
13	Maximum duration of the conversion cycle	2 s
14	Limits of permissible additional error EOS caused by deviation of supply voltage from nominal 230 VAC in the operating range	± 0.1% (F.S.)
15	Limits of permissible additional error EOS caused by the deviation of the ambient temperature from 20°C to any temperature within the operating temperature range for every 10°C	± 0.2% (F.S.)
16	Overall dimensions	140x96x40 mm

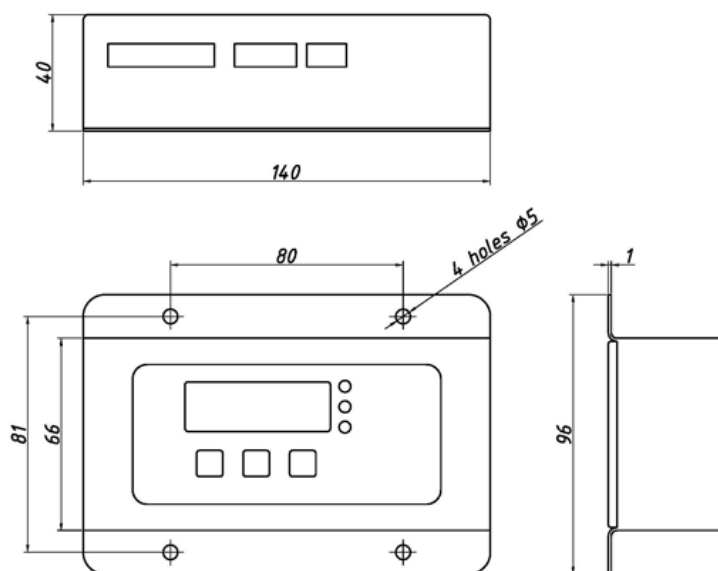

**Figure 1**

The instrument is adjusted by the function buttons located on the front panel, the general view of which is shown in Figure 2.

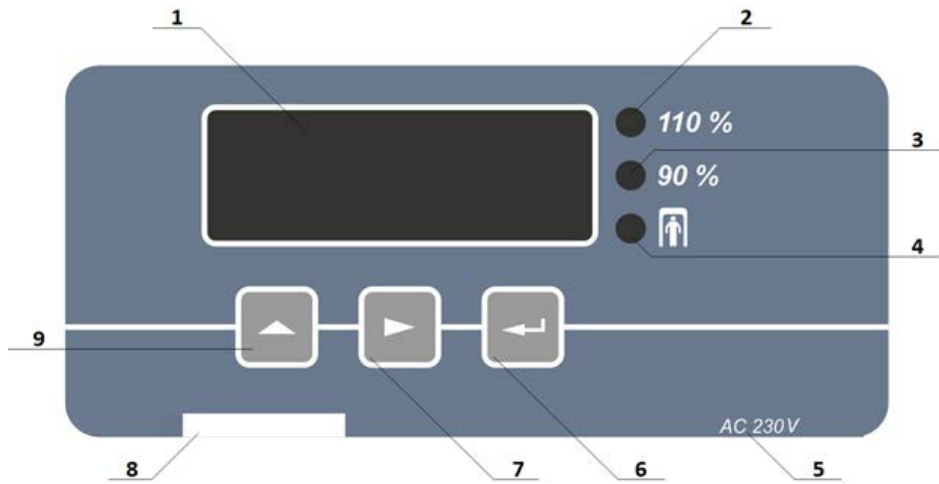

**Figure 2**

The purpose of the front panel elements is shown in Table 4.

**Table 4**

No	Name
1	LED Display
2	Overload LED indicator
3	90% load LED
4	Passenger presence LED
5	Power supply information
6	Parameter selection / Enter
7	Move flashing digit to right
8	Serial number
9	Increasing the flashing digit / Go to the next parameter / Perform Zeroing

The purpose of the terminals of the connection block is shown in Figure 3.

Standard option connections:

Optional additional connections:

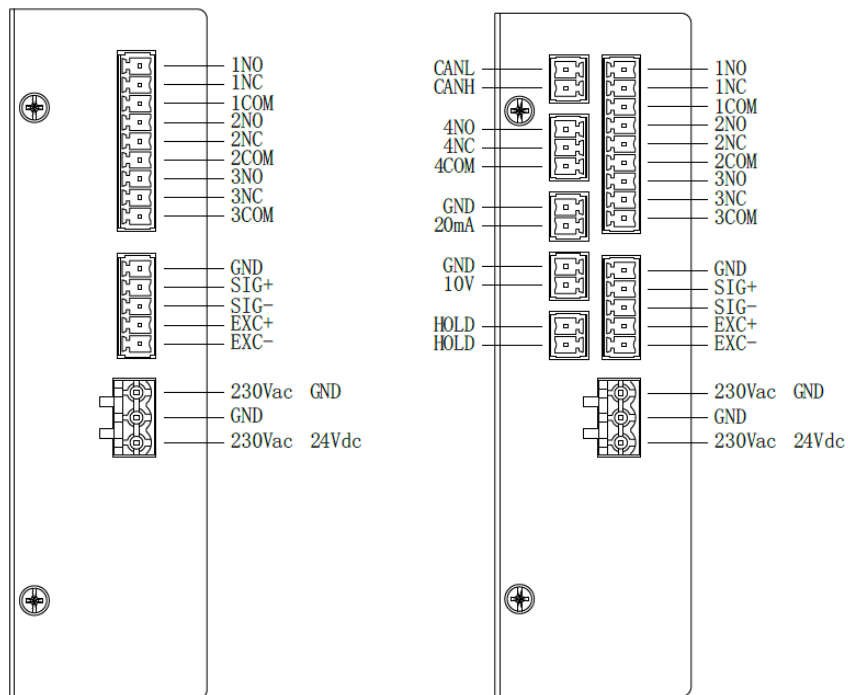

NO: Normal Open; NC: Normal Close.

**Figure 3**

The pin markings are printed on the case under the connectors. The pin assignments on the terminal block are given in Table 5.

**Table 5**

Designation	Connector	Description
1NO	NO relay PP	Normally open output of the relay “passenger presence”
1NC	NC relay PP	Normally closed output of the relay “passenger presence”
1COM	Input relay PP	Input of the relay “passenger presence”
2NO	NO relay 90%	Normally open relay 90% of the nominal capacity
2NC	NC relay 90%	Normally closed relay 90% of the nominal capacity
2COM	Input relay 90%	Input relay 90% of the nominal capacity
3NO	NO relay 110%	Normally open relay 110% of the nominal capacity
3NC	NC relay 110%	Normally closed relay 110% of the nominal capacity
3COM	Input relay 110%	Input relay 110% of the nominal capacity
GND	Ground of load cells	Ground of load cells
SIG+	Load cell signal +	Load cell signal (positive polarity)
SIG-	Load cell signal -	Load cell signal (negative polarity)
EXC+	Load cell power +	Load cell power (positive polarity)
EXC-	Load cell power -	Load cell power (negative polarity)
230Vac / GND	Power supply / GND	Power supply (for 230VAC) / GND (for 24VDC)
GND	Ground	Main ground
230Vac / 24Vdc	Power supply	Power supply (for 230VAC) / Power supply (for 24VDC)
Options:		
CANL	CAN bus (-)	CAN interface (low level)
CANH	CAN bus (+)	CAN interface (high level)
4NO	NO relay 50%	Normally open relay 50% of the overweight
4NC	NC relay 50%	Normally closed relay 50% of the overweight
4COM	Input relay 50%	Input relay 50% of the overweight
GND	Analog output (-)	Analog current output interface (0-20mA), signal -
20mA	Analog output (+)	Analog current output interface (0-20mA), signal +
GND	Analog output (-)	Analog voltage output interface (0-10V), signal -
10V	Analog output (+)	Analog voltage output interface (0-10V), signal +
HOLD	Disabling input	Input of disabling signal (24VDC/240VAC)
HOLD	Disabling input	Input of disabling signal (24VDC/240VAC)

## EOS-4 control unit

№	Parameter name	Value
1	Power supply	230±20 VAC 50±1 Hz 24±4 VDC (optional)
2	Power consumption, no more than	5 W
3	Maximum current switched by relay outputs at voltage 220VAC or 24 VDC	10 A
4	Operating mode	continuous
5	Number of programmable relay outputs	3 or 4
6	Setting threshold range loading  presence of a passenger 50% 90% 110%	Set in kg 0-50 kg 0-9999 kg 0-9999 kg 0-9999 kg
7	Number of digits of the display	5
8	Operating temperature range	-10...+40°C
9	Humidity	15...95%
10	Degree of protection for IEC 60529 (DIN 40050)	IP20
11	Average full-service life, not less than	10 years
12	Lower limit of transformations	1 or 5 kg
13	Maximum duration of the conversion cycle	2 s
14	Limits of permissible additional error EOS caused by deviation of supply voltage from nominal 230 VAC in the operating range	± 0.1% (F.S.)
15	Limits of permissible additional error EOS caused by the deviation of the ambient temperature from 20°C to any temperature within the operating temperature range for every 10°C	± 0.2% (F.S.)
16	Overall dimensions	93x89x28 mm

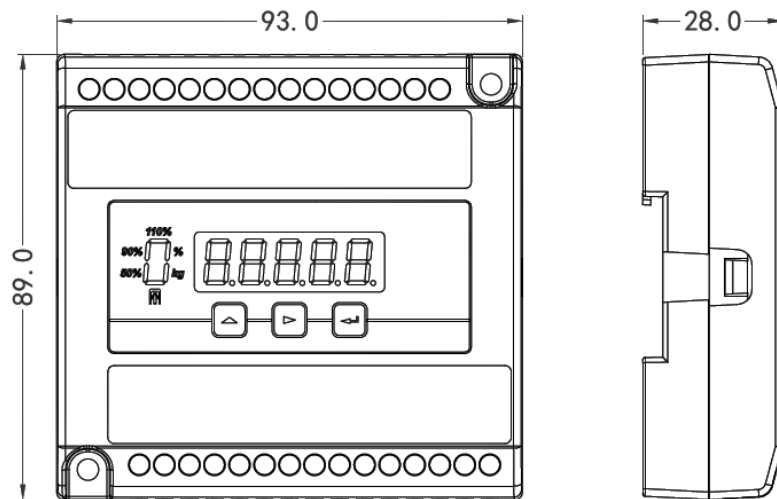

**Figure 4**

The instrument is adjusted by the function buttons located on the front panel, the general view of which is shown in Figure 5.



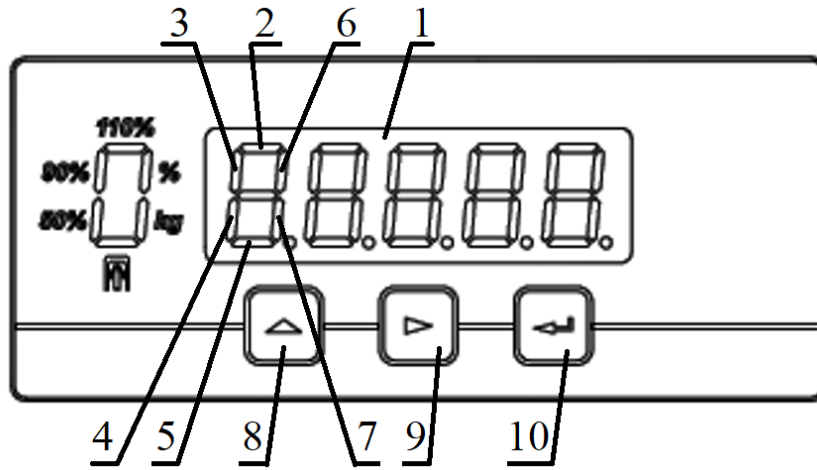

Figure 5

The purpose of the front panel elements is shown in Table 6.

Table 6

№	Name
1	LED Display
2	Overload LED indicator
3	90% load LED
4	50% load LED
5	Passenger presence LED
6	Load displayed in “%” from elevator capacity
7	Load displayed in “kg”
8	Increasing the flashing digit / Go to the next parameter / Perform Zeroing / Change displayed value “kg” or “%”
9	Move flashing digit to right
10	Parameter selection / Enter

The purpose of the terminals of the connection block is shown in Figure 6.

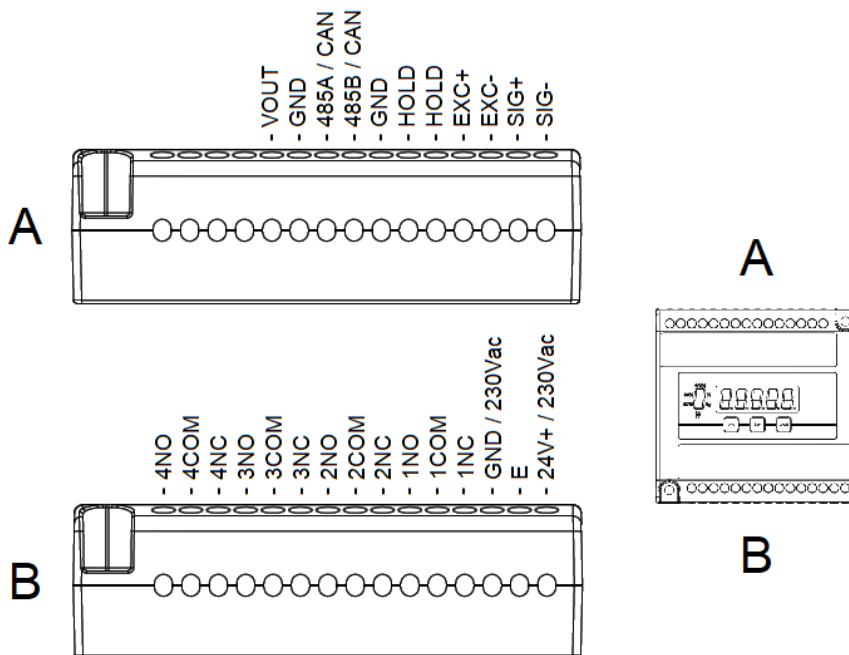

Figure 6

The pin markings are printed on the case under the connectors. The pin assignments on the terminal block are given in Table 7.

**Table 7**

Designation	Connector	Description
1NO	NO relay PP	Normally open output of the relay “passenger presence”
1NC	NC relay PP	Normally closed output of the relay “passenger presence”
1COM	Input relay PP	Input of the relay “passenger presence”
2NO	NO relay 50%	Normally open relay 50% of the overweight
2NC	NC relay 50%	Normally closed relay 50% of the overweight
2COM	Input relay 50%	Input relay 50% of the overweight
3NO	NO relay 90%	Normally open relay 90% of the nominal capacity
3NC	NC relay 90%	Normally closed relay 90% of the nominal capacity
3COM	Input relay 90%	Input relay 90% of the nominal capacity
4NO	NO relay 110%	Normally open relay 110% of the nominal capacity
4NC	NC relay 110%	Normally closed relay 110% of the nominal capacity
4COM	Input relay 110%	Input relay 110% of the nominal capacity
SIG+	Load cell signal +	Load cell signal (positive polarity)
SIG-	Load cell signal -	Load cell signal (negative polarity)
EXC+	Load cell power +	Load cell power (positive polarity)
EXC-	Load cell power -	Load cell power (negative polarity)
24V+ / 230Vac	Power supply	Power supply 230Vac or 24Vdc(+) (optional)
E	Power ground	Power ground
GND / 230Vac	Power supply	Power supply 230Vac or 24Vdc(-) (optional)
Options:		
485A / CAN	Data output	Data connection (options: RS-485, RS-232 or CAN)
485 B / CAN	Data input	Data connection (options: RS-485, RS-232 or CAN)
GND	Data GND	Data connection (options: RS-485, RS-232 or CAN)
VOUT	Analog output (+)	Analog voltage output interface (0-10V), signal +
GND	Analog output (-)	Analog voltage output interface (0-10V), signal -
AOUT	Analog output (+)	Analog current output interface (0-20mA), signal +
GND	Analog output (-)	Analog current output interface (0-20mA), signal -
HOLD	Disabling input	Input of disabling signal (24VDC/240VAC)
HOLD	Disabling input	Input of disabling signal (24VDC/240VAC)

## 13. Description of the load cells models

### EOS-A load cell

#### Technical information

No	Parameter name	Value
1	Maximum load (F.S.) on individual load cell	1000 kg
2	Degree of protection for IEC 60529 (DIN 40050)	IP67
3	Average full-service life, not less than	10 years
4	Upper conversion limit (F.S.) – for a set of 2 load cells	2000 kg
5	Limits of permissible reduced basic conversion error	± 0.5% (F.S.)
6	Overall dimensions	140xØ30 mm
7	Cable length:	
	From load cell to junction box	1000 mm
	From junction box to indicator	5000 mm

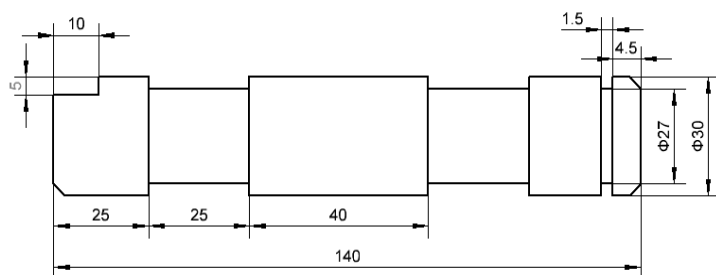

Figure 7

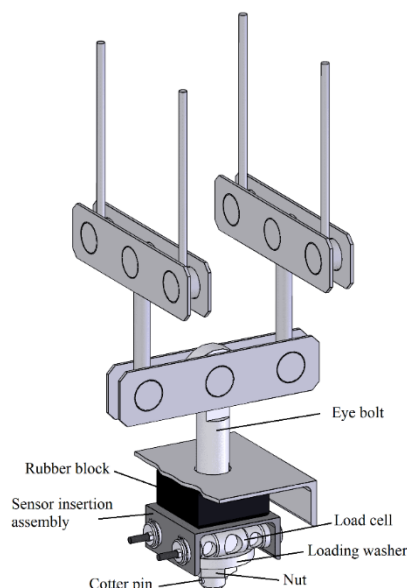

Figure 8

#### Installation

The location of the load cell in a balance suspension is shown in Figure 8.

Install the load cells into the sensor insertion assembly and fix it with the fixing plates. Install the insertion assembly with the load cells on the central balancing eye bolt under the shock-absorbing rubber block. Fix the installation unit with a loading washer. Tighten the loading washer with counter nut. Install the safety cotter pin in the eye bolt. Lower the elevator cabin onto the sensor insertion assembly.

Insertion assembly, eye bolt, loading washer, counter nut and cotter pin are not included in the delivery set.

Wires color marking from junction box shown in Table 8.

Table 8

Color marking	Function	Designation
Red	Power supply +	(+U <sub>in</sub> )
Black	Power supply -	(-U <sub>in</sub> )
Green	Output signal +	(+U <sub>out</sub> )
White	Output signal -	(-U <sub>out</sub> )

## EOS-B load cell

### Technical information

№	Parameter name	Value
1	Maximum load (F.S.) on individual load cell	800 kg
2	Degree of protection for IEC 60529 (DIN 40050)	IP67
3	Average full-service life, not less than	10 years
4	Upper conversion limit (F.S.) – for a set of 4 load cells	3200 kg
5	Limits of permissible reduced basic conversion error	± 0.5% (F.S.)
6	Overall dimensions	190x45x47.5 mm
7	Cable length:	
	From load cell to junction box	1500 mm
	From junction box to indicator	5000 mm

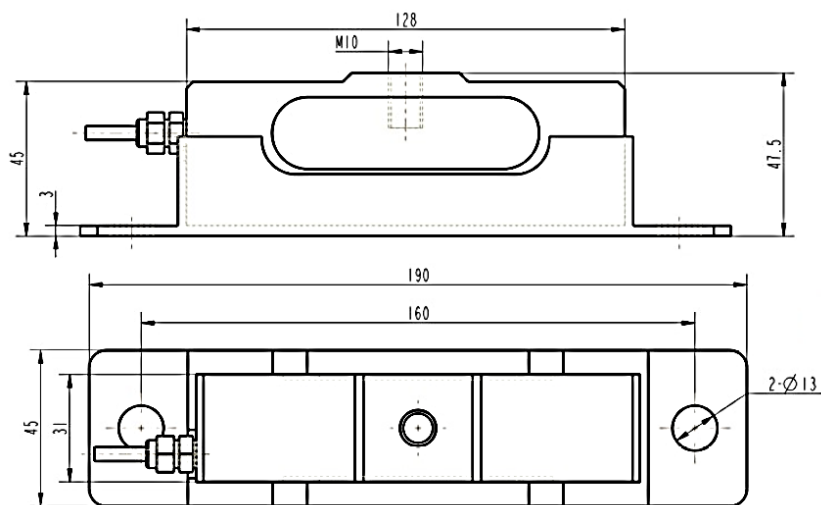

**Figure 9**

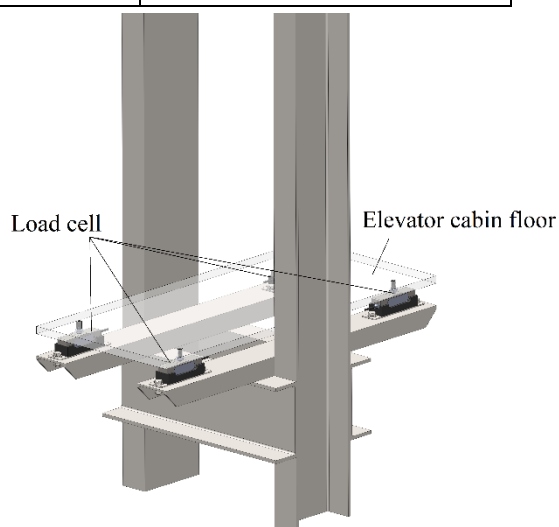

**Figure 10**

### Installation

After carrying out preparatory work, it is necessary to install the load cells on the support frame of the elevator and fasten them with M12 bolts, without tightening them to the end.

The location of the load cell is shown in Figure 10.

Mount the elevator cabin on the load cells in such a way that the mounting holes of the cabin line up with the mounting holes of the load cells. In case of mismatch of the mounting holes, change the location of the load cell in the horizontal plane on the support frame until they completely match and fix to the elevator cabin by screwing the studs all the way into the load cells, and then fix the stud with a locknut.

Wires color marking from junction box shown in Table 9.

**Table 9**

Color marking	Function	Designation
Red	Power supply +	(+U <sub>in</sub> )
Black	Power supply -	(-U <sub>in</sub> )
Green	Output signal +	(+U <sub>out</sub> )
White	Output signal -	(-U <sub>out</sub> )

## EOS-B1 load cell

### Technical information

№	Parameter name	Value
1	Maximum load (F.S.) on individual load cell	3000 kg
2	Degree of protection for IEC 60529 (DIN 40050)	IP67
3	Average full-service life, not less than	10 years
4	Upper conversion limit (F.S.) – for a set of 1 load cell	3000 kg
5	Limits of permissible reduced basic conversion error	± 0.5% (F.S.)
6	Overall dimensions	130x31.8x31.8 mm
7	Cable length: From load cell to indicator	2500 mm

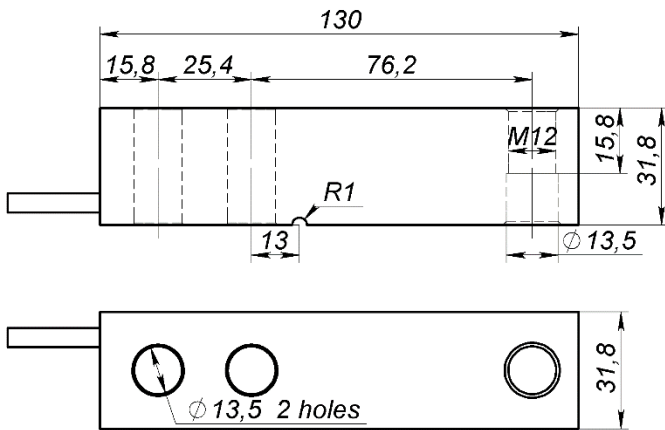

**Figure 11**

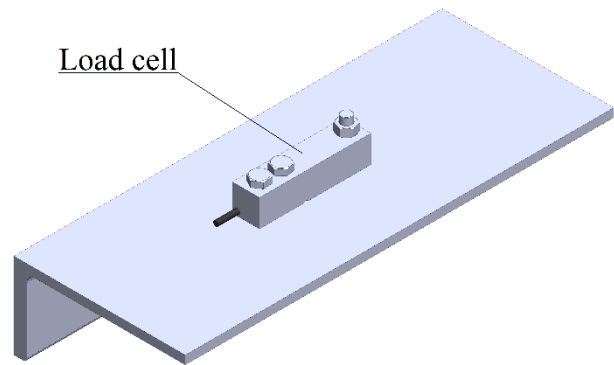

**Figure 12**

### Installation

Install the load cell on a base frame of elevator, as shown in Figure 12 and fix tightly with bolts and nuts.

The location of the load cell is shown in Figure 12.

Mount the elevator cabin on the load cells in such a way that the mounting holes of the cabin line up with the mounting holes of the load cells. In case of mismatch of the mounting holes, change the location of the load cell in the horizontal plane on the support frame until they completely match and fix to the elevator cabin by screwing the studs all the way into the load cells, and then fix the stud with a locknut.

Wires color marking from load cell (or from junction box for sets of more than 1 load cell) shown in Table 10.

**Table 10**

Color marking	Function	Designation
Red	Power supply +	(+U <sub>in</sub> )
Black	Power supply -	(-U <sub>in</sub> )
Green	Output signal +	(+U <sub>out</sub> )
White	Output signal -	(-U <sub>out</sub> )

## EOS-C load cell

### Technical information

№	Parameter name	Value
1	Maximum load (F.S.) on individual load cell	1000 kg
2	Degree of protection for IEC 60529 (DIN 40050)	IP67
3	Average full-service life, not less than	10 years
4	Upper conversion limit (F.S.) – for a set of 4 load cells	4000 kg
5	Limits of permissible reduced basic conversion error	± 0.5% (F.S.)
6	Overall dimensions	200x80x47 mm
7	Cable length:  From load cell to junction box From junction box to indicator	1500 mm 6000 mm

Studs and nuts are included in the kit EOS-C(1). Kit EOS-C is fully the same, but without studs and nuts.

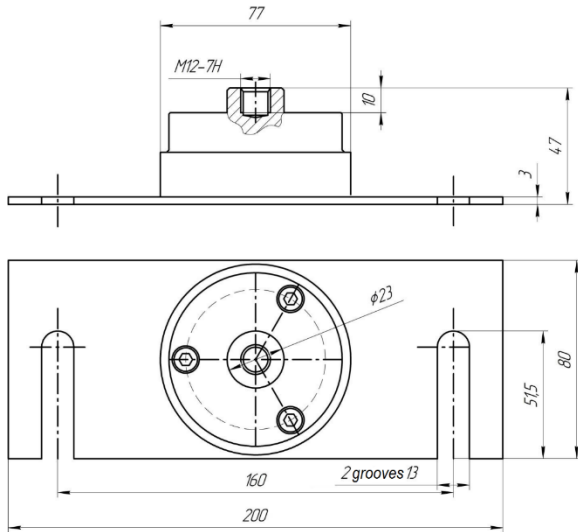

**Figure 13**

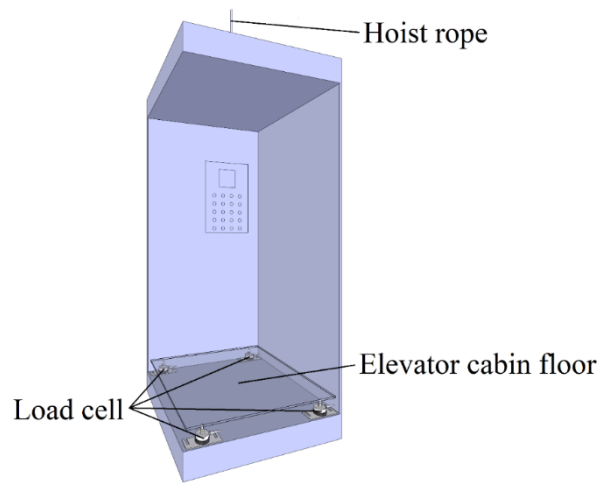

**Figure 14**

### Installation

After carrying out preparatory work, it is necessary to install the load cells on the support frame of the elevator and fasten them with M12 bolts, without tightening them to the end.

The location of the load cell is shown in Figure 14.

Mount the elevator cabin on the load cells in such a way that the mounting holes of the cabin line up with the mounting holes of the load cells. In case of mismatch of the mounting holes, change the location of the load cell in the horizontal plane on the support frame until they completely match and fix to the elevator cabin by screwing the studs all the way into the load cells, and then fix the stud with a locknut.

Wires color marking from junction box shown in Table 11.

**Table 11**

Color marking	Function	Designation
Red	Power supply +	(+U <sub>in</sub> )
Black	Power supply -	(-U <sub>in</sub> )
Green	Output signal +	(+U <sub>out</sub> )
White	Output signal -	(-U <sub>out</sub> )

## EOS-CS load cell

### Technical information

№	Parameter name	Value
1	Maximum load (F.S.) on individual load cell	1000 kg
2	Degree of protection for IEC 60529 (DIN 40050)	IP67
3	Average full-service life, not less than	10 years
4	Upper conversion limit (F.S.) – for a set of 4 load cells	4000 kg
5	Limits of permissible reduced basic conversion error	± 0.5% (F.S.)
6	Overall dimensions	200x60x46 mm
7	Cable length:	
	From load cell to junction box	1500 mm
	From junction box to indicator	5000 mm

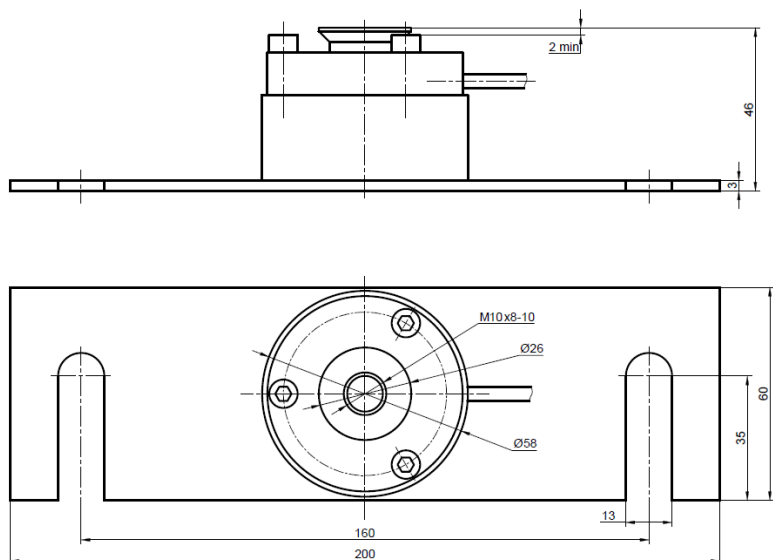

**Figure 15**

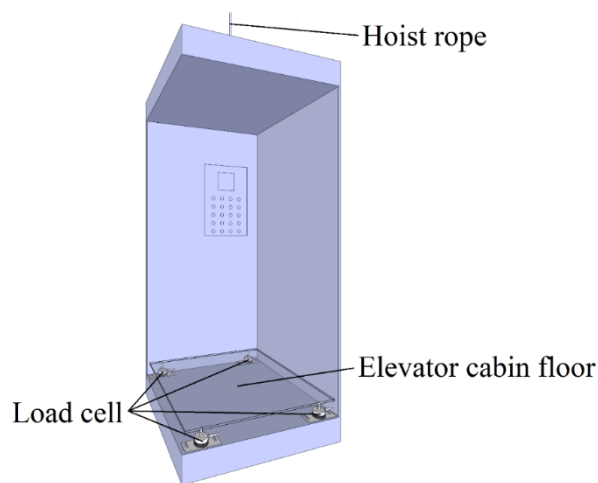

**Figure 16**

### Installation

After carrying out preparatory work, it is necessary to install the load cells on the support frame of the elevator and fasten them with M10 bolts, without tightening them to the end.

The location of the load cell is shown in Figure 16.

Mount the elevator cabin on the load cells in such a way that the mounting holes of the cabin line up with the mounting holes of the load cells. In case of mismatch of the mounting holes, change the location of the load cell in the horizontal plane on the support frame until they completely match and fix to the elevator cabin by screwing the studs all the way into the load cells, and then fix the stud with a locknut.

Wires color marking from junction box shown in Table 12.

**Table 12**

Color marking	Function	Designation
Red	Power supply +	(+U <sub>in</sub> )
Black	Power supply -	(-U <sub>in</sub> )
Green	Output signal +	(+U <sub>out</sub> )
White	Output signal -	(-U <sub>out</sub> )

## EOS-R load cell

### Technical information

№	Parameter name	Value
1	Maximum load (F.S.) on individual load cell	1000 kg
2	Degree of protection for IEC 60529 (DIN 40050)	IP67
3	Average full-service life, not less than	10 years
4	Upper conversion limit (F.S.) – for a set of 3 load cells	3000 kg
5	Limits of permissible reduced basic conversion error	$\pm 0.5\%$ (F.S.)
6	Overall dimensions	95x52x52 mm
7	Cable length:	
	From load cell to junction box	1500 mm
	From junction box to indicator	5000 mm

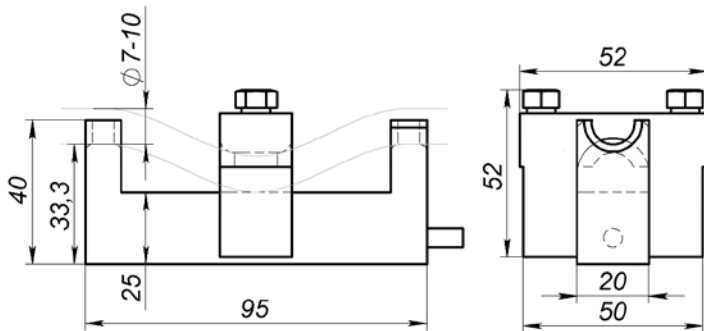

**Figure 17**

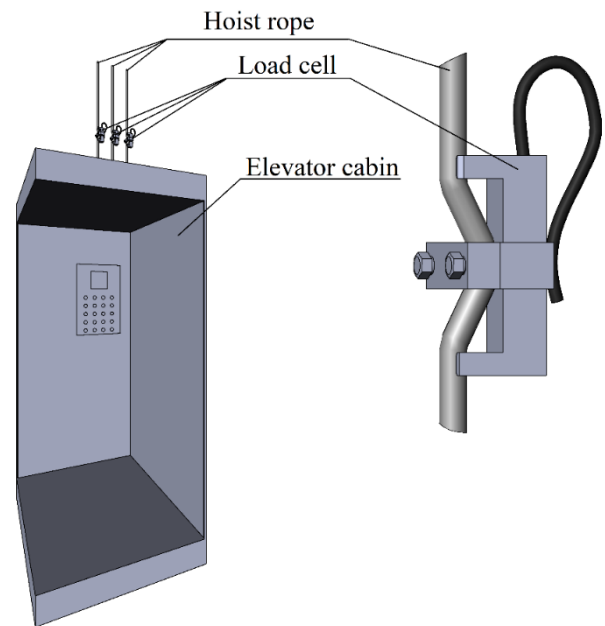

**Figure 18**

### Installation

The location of the load cell on hoist ropes is shown in Figure 18. Tighten the mounting bolts of the load cells and secure the lead cables.

Mount the elevator cabin on the load cells in such a way that the mounting holes of the cabin line up with the mounting holes of the load cells. In case of mismatch of the mounting holes, change the location of the load cell in the horizontal plane on the support frame until they completely match and fix to the elevator cabin by screwing the studs all the way into the load cells, and then fix the stud with a locknut.

Wires color marking from junction box shown in Table 13.

**Table 13**

Color marking	Function	Designation
Red	Power supply +	(+U <sub>in</sub> )
Black	Power supply -	(-U <sub>in</sub> )
Green	Output signal +	(+U <sub>out</sub> )
White	Output signal -	(-U <sub>out</sub> )



## EOS-R1 load cell

### Technical information

№	Parameter name	Value
1	Maximum load (F.S.) on individual load cell	3000 kg
2	Degree of protection for IEC 60529 (DIN 40050)	IP67
3	Average full-service life, not less than	10 years
4	Upper conversion limit (F.S.) – for a set of 1 load cell	3000 kg
5	Limits of permissible reduced basic conversion error	$\pm 0.5\%$ (F.S.)
6	Overall dimensions	208x175x103 mm
7	Cable length: From load cell to indicator	3000 mm

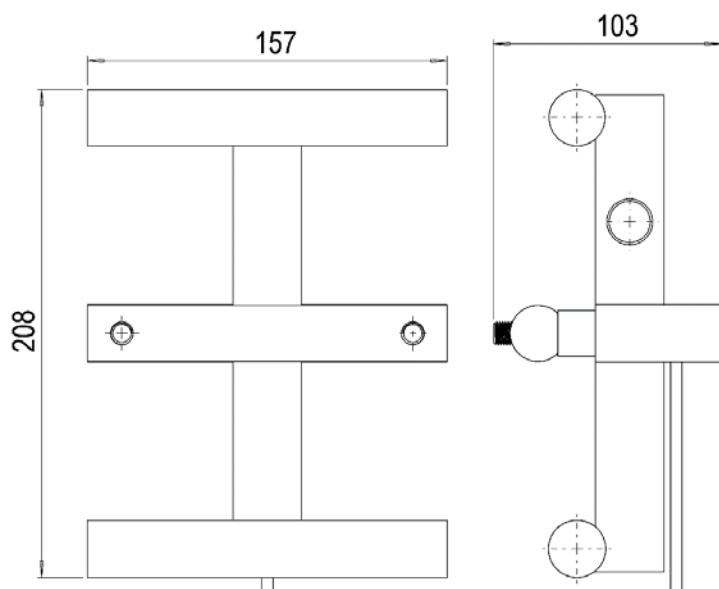

**Figure 19**

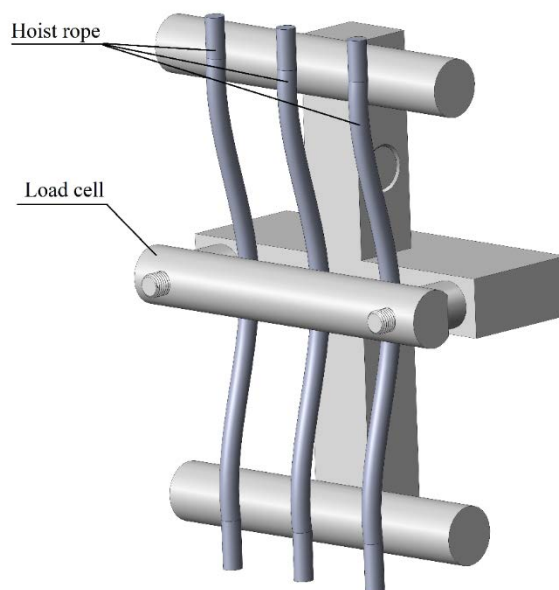

**Figure 20**

### Installation

The location of the load cell on hoist ropes is shown in Figure 20. Tighten the mounting bolts of the load cells and secure the lead cables.

Mount the elevator cabin on the load cells in such a way that the mounting holes of the cabin line up with the mounting holes of the load cells. In case of mismatch of the mounting holes, change the location of the load cell in the horizontal plane on the support frame until they completely match and fix to the elevator cabin by screwing the studs all the way into the load cells, and then fix the stud with a locknut.

Wires color marking from load cell (or from junction box for sets of more than 1 load cell) shown in Table 14.

**Table 14**

Color marking	Function	Designation
Red	Power supply +	(+U <sub>in</sub> )
Black	Power supply -	(-U <sub>in</sub> )
Green	Output signal +	(+U <sub>out</sub> )
White	Output signal -	(-U <sub>out</sub> )

## EOS-W load cell

### Technical information

№	Parameter name	Value
1	Maximum load (F.S.) on individual load cell	1000 kg
2	Degree of protection for IEC 60529 (DIN 40050)	IP67
3	Average full-service life, not less than	10 years
4	Upper conversion limit (F.S.) – for a set of 3 load cells	3000 kg
5	Limits of permissible reduced basic conversion error	± 0.5% (F.S.)
6	Overall dimensions	Ø45x20 mm
7	Cable length:	
	From load cell to junction box	1000 mm
	From junction box to indicator	5000 mm

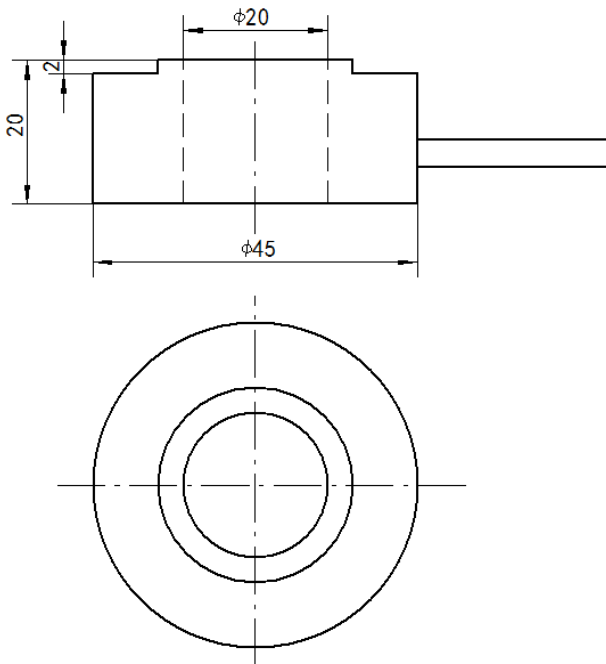

**Figure 21**

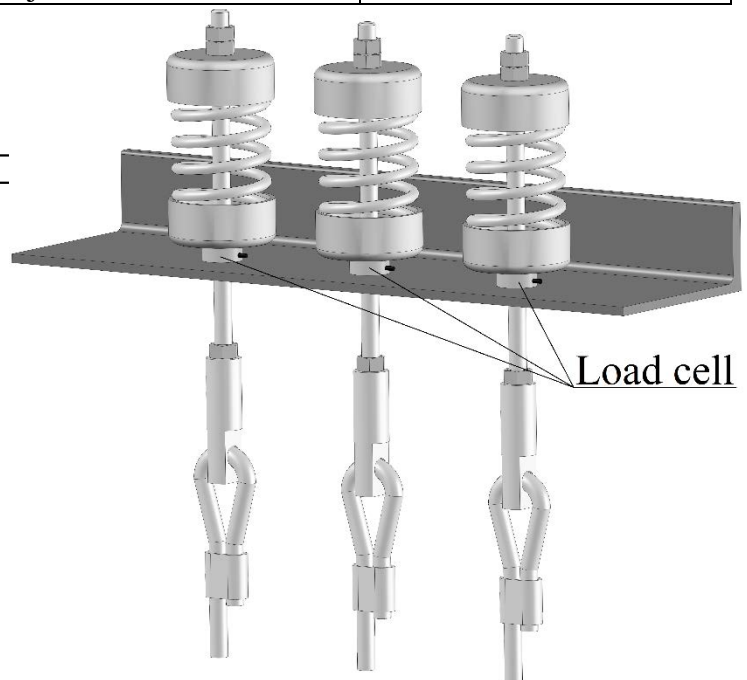

**Figure 22**

### Installation

The location of the load cell under springs is shown in Figure 22.

Install the load cells under the spring suspension, an example is shown in the Figure 22. Thread the eye traction bolts into the sensors. Put a set of washers and springs on the bolts. Tighten and secure the suspension with a locknut.

Lower the elevator cabin onto the sensors, paying attention to the uniform tension of the ropes (weight distribution on the load cells). If the tension of the ropes is uneven, adjust their spring tension with the locknuts.

Wires color marking from junction box shown in Table 15.

**Table 15**

Color marking	Function	Designation
Red	Power supply +	(+U <sub>in</sub> )
Black	Power supply -	(-U <sub>in</sub> )
Green	Output signal +	(+U <sub>out</sub> )
White	Output signal -	(-U <sub>out</sub> )

## EOS-W1 load cell

### Technical information

№	Parameter name	Value
1	Maximum load (F.S.) on individual load cell	1000 kg
2	Degree of protection for IEC 60529 (DIN 40050)	IP65
3	Average full-service life, not less than	10 years
4	Upper conversion limit (F.S.) – for a set of 4 load cells	4000 kg
5	Limits of permissible reduced basic conversion error	$\pm 0.5\%$ (F.S.)
6	Overall dimensions	$\text{Ø}40 \times 30 \times 40$ mm
7	Cable length:	
	From load cell to junction box	1000 mm
	From junction box to indicator	5000 mm

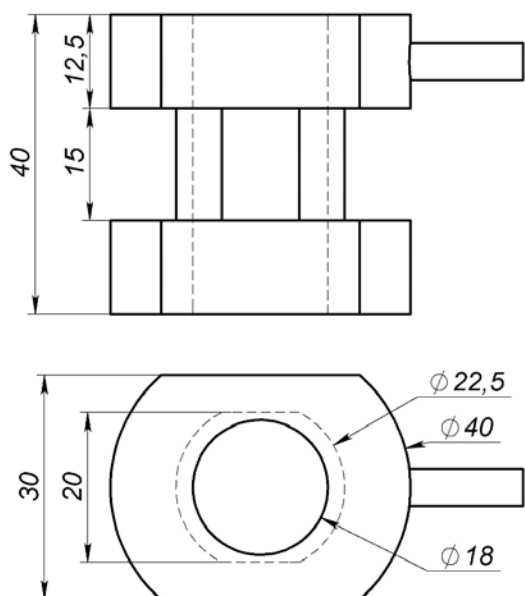

**Figure 23**

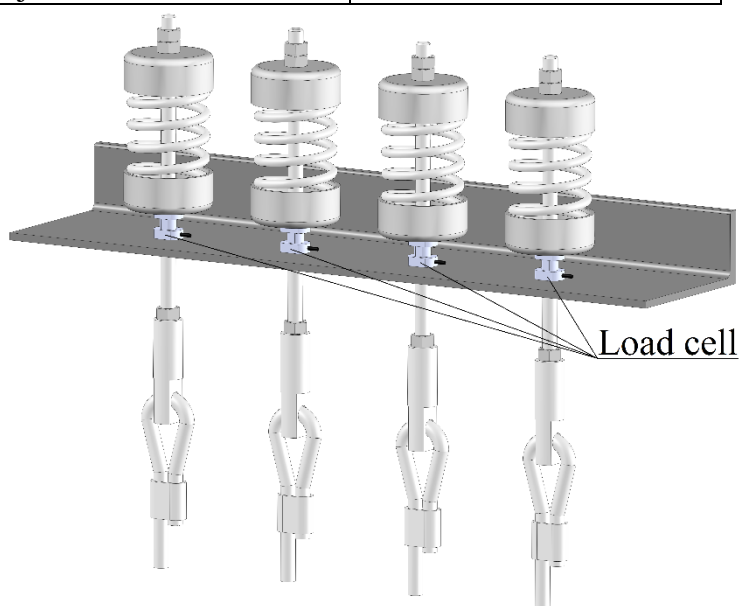

**Figure 24**

### Installation

The location of the load cell under springs is shown in Figure 24.

Install the load cells under the spring suspension, an example is shown in the Figure 24. Thread the eye traction bolts into the sensors. Put a set of washers and springs on the bolts. Tighten and secure the suspension with a locknut.

Lower the elevator cabin onto the sensors, paying attention to the uniform tension of the ropes (weight distribution on the load cells). If the tension of the ropes is uneven, adjust their spring tension with the locknuts.

Wires color marking from junction box shown in Table 16.

**Table 16**

Color marking	Function	Designation
Red	Power supply +	(+U <sub>in</sub> )
Black	Power supply -	(-U <sub>in</sub> )
Green	Output signal +	(+U <sub>out</sub> )
White	Output signal -	(-U <sub>out</sub> )